

IN-SITU ZIRCONIA OXYGEN ANALYZER < ZIRCOMAT-C >

DATA SHEET

ZFK, ZRY

This oxygen analyzer is used to continuously measure oxygen concentration in combustion exhaust gas of industrial boilers or furnaces, and is ideally suited for combustion monitoring and control.

The detector (ZFK) used with the analyzer is directly inserted into the objects measured, eliminating the need for a sampling device and provides quick response.

The converter (ZRY) features 3 measuring ranges, one touch calibration and NEMA4 housing.

Comparing to the current converter (ZRM), this ZRY is recognized as economical type with simple functions.



General-use detector



Converter

FEATURES

1. Sampling device is unnecessary

Gas sampling devices such as a gas aspirator, a dehumidifier, etc. are unnecessary because of use of direct-insertion type detector.

2. High speed response

The adoption of a flow guide tube utilizing the flow of the measured gas assures quick response (less than 7sec).

3. Dust-tight and water-proof housing

Aluminum die casting housing of converter satisfies NEMA4 and IP65 standard.

4. 3-measuring ranges and one touch calibration

The converter has 0-5, 10, 25 vol% 3 ranges easily changed by pin connection and zero and span are simply calibrated by key operation.

SPECIFICATIONS

General

Measuring object:	Oxygen contained in noncombustible gas
Measuring principle:	Direct-insertion zirconia system
Measuring range:	0 to 5, 10 or 25 vol% O ₂ (Changed by internal set pin)
Repeatability:	Within ±1.0% of full scale
Linearity:	±2% of full scale
Response time:	Within 7sec for 90% response (from calibration gas inlet)
Power supply:	100, 115, 220 or 230V AC, 50/60Hz
Power consumption:	
(approx.)	15 + 50VA (at steady state)
	15 + 200VA (at start)
Warmup time:	Approx. 15min

Oxygen detector (ZFK2, 5)

Measuring detector:

For general-use: ZFK2
For corrosive gas: ZFK5

Measured gas temperature:

Flow guide tube system; -20 to +600°C

Measured gas pressure:

-3 to +3kPa

Flow guide tube:

Flange; JIS5K 65A FF
(JIS5K-80AFF for high particulate gas)
Insertion length; 0.3, 0.5, 0.75, 1m
(0.8m for high particulate gas)

Ambient temperature:

-20 to +60°C for cable section
125°C or less at detector flange surface with power applied

Structure:

Dust/rain-proof structure(IEC IP55 equivalent)

Filter:

Alumina(filtering accuracy 50μm) and quartz paper

Main materials of gas-contacting parts:

General-use detector(ZFK 2); Zirconia, SUS316, platinum, SUS304
Anticorrosive detector(ZFK 5); Zirconia, titanium, platinum, SUS316
Flow guide tube; SUS304 or SUS316

Calibration gas inlet:

Brass joint for $\phi 1/4$ inch tube.

Reference air inlet (option):

Rc1/8 or NPT1/8

Detector mounting:

Horizontal plane $\pm 45^\circ$, ambient surrounding air should be clean.

Outer dimensions: (L x max. dia.) 210mm x 100mm

(detector)

Mass (approx.) {weight}:

Detector; 1.6kg
Flow guide tube (general-use, 1m); 5kg

Finish color:

Silver and SUS metallic color

Oxygen converter (ZRY)

Measuring range: 0-5, 10, 25 vol% O₂

Changeable by internal set pin.

Repeatability:

$\pm 1.0\%$ of full scale

Linearity:

$\pm 2.0\%$ of full scale

Indication:

Oxygen concentration; 3-digit LED

Oxygen concentration output signal:

4 to 20mA DC (allowable load resistance: 500 Ω or less)

Isolated output, linear

Fault contact output:

250V AC, 2A rating (close contact or open contact for fault should be specified when you place an order.)

Self-diagnoses:

Fault of sensor temperature, zero calibration error, span calibration error

Calibration method:

Manual calibration with key operation

Calibration gas: • Recommended calibration gas concentration

Zero gas; 1.0 to 2.0% O₂

Span gas; 20.6 to 21.0% O₂
(oxygen concentration in the air)

Ambient temperature:

-10 to +50°C

Ambient humidity: 90% RH or less

Power supply: 90 to 220 or 230 V AC, 50/60Hz

Construction: Dust-tight, waterproof construction, NEMA4 (corresponding to IP65 of IEC)

Material: Aluminum die casting

Outer dimensions (H x W x D):

220 X 230 X 95mm

Mass {weight}: Approx. 4.5kg (excluding cable and detector)

Finish color: Munsell 6PB 3.5/10.5 (blue): cover, silver; case

Mounting method: Mounted flush on panel

Exclusion cable (ZRZP)

Cable: 4-cores sealed wire (O₂ signal and R-themo couple signal) and 2-cores cable (power)

Cable conduit: Flexible type

Length: Refer to code symbols

SCOPE OF DELIVERY

Detector: Detector main unit x 1, Viton O ring x 1, mounting screw (M5mm x 12) x 6, thermal sticker x 1, flow guide tube (as specified) x 1, ceramic filter x 1, cover (as specified) x 1, reference air inlet (as specified) x 1

Converter: Converter main unit x 1
Accessories (AC250V 500mA T fuse x 1, AC250V 3.15A T fuse x 1)

Items to be prepared separately:

- (1) Standard gas for calibration
Type ZBM□NSK4-01
- (2) Reduction valve for standard gas (type ZBD61003)
- (3) Flowmeter
Type; ZBD52203, 0.2 to 2L/min (for calibrating gas)

CAUTIONS

- If combustible gas (CO, H₂ etc.) exists in the measured gas, error will occur due to burning at the sensor section. The inclusion of corrosive gas (Si vapor, alkaline metal, P, Pb etc.) will shorten the life of the sensor.
- When the measured gas temperature is high (+300°C or higher), the flange should be separated from the furnace wall in order to bring the detector flange surface temperature below the specified value +125°C). The flow guide should be attached in the direction in which the gas flow to the detector decreases.
- When dust more than 1g/Nm³ is included in the gas, manual blow down is necessary.

The product conforms to the requirements of the Electromagnetic compatibility Directive 89/336/EEC as detailed within the technical construction file number TZ737041. The applicable standards used to demonstrate compliance are :

EN 55011 : 1992 CLASSA Conducted and Radiated emissions

EN 50082-1 : 1992 Radiated immunity, ESD and FBT

DEVICE CONFIGURATION

The device to be combined differ according to the conditions of the gas to be measured. Please select the devices to be combined with reference to the following table.

Measured gas						Device configuration		
Application	Temperature	Gas Flow	DUST	Protection cover	Note	Detector type	Converter type	Ejector type
General-use (boiler) Anti-corrosive use (incinerator)	600°C or less	5 to 20m/s	Less than 0.2g/m ³ [nor]	—	Fuel; gas, oil	ZFK□R□□4-□□□□□□	ZRY	—
			Less than 10g/m ³ [nor]	no	Fuel: coal with manual blow down	ZFK□R□□4-□D□□□□	ZRY	—
			Less than 25g/m ³ [nor]	yes	Included high moisture with manual blow down	ZFK□R□□4-□E□□□□	ZRY	—

Note (1) Dust volume is approximate value.

(2) Instrument quality air or bottled air is available as reference air by selecting detector with reference air inlet, when oxygen concentration in air around sensor changes.

CODE SYMBOLS

(Detector)

ZFK				Description								
4	5	6	7	8	9	10	11	12	13			
R	2	4								Application		
										General use.		
										For corrosive gas (refuse incinerator)		
										Cal. gas inlet		
										For φ1/4 inch tube		
										Power supply		
										100/115VAC 50/60Hz		
										200/220VAC 50/60Hz		
										230VAC 50/60Hz (CE-marking approved)		
										Flow guide tube		
										flange	application	length
										0 Y 0	None	
										5 A 3	SUS304 general use	300mm
										5 A 5	SUS304 general use	500mm
										5 A 7	SUS304 general use	750mm
										5 A 1	SUS304 general use	1000mm
										5 B 3	SUS316 for corrosive gas	300mm
										5 B 5	SUS316 for corrosive gas	500mm
										5 B 7	SUS316 for corrosive gas	750mm
										5 B 1	SUS316 for corrosive gas	1000mm
										6 D 8	SUS316 for high particulate	800mm
										6 E 8	SUS316 for high particulate with cover	800mm
										Protection cover		
										Y	Without	
										A	With	
										Reference air inlet		
										Y	Non	
										A	Rc1/8	
										B	NPT1/8	

(Converter)

ZRY1Y12-1R0												Description	
1	2	3	4	5	6	7	8	9	10	11	12		
Z	R	Y	1	Y	1	2		1	R	0		Output signal and fault output	
												4 to 20mA DC, close contact	
												4 to 20mA DC, open contact	
												Power supply	
												90 to 230V AC 50/60Hz (CE marking approved)	
												Mounting method	
												Panel mounting	
												Instruction manual	
											Y	NO	
											E	YES (English)	

(Exclusive-special cable)

ZRPZPR1-□									Description		
1	2	3	4	5	6	7	8	9			
Z	R	Z	P	R	1				Connectable devices		
									For ZRY		
									Types		
									For R thermocouple		
									Conduit length	Cable length	
									YA	None	6m
									YB	None	10m
									YC	None	15m
									YD	None	20m
									YE	None	30m
									YF	None	40m
									YG	None	50m
									YH	None	60m
									YJ	None	70m
									YK	None	80m
									YL	None	90m
									YM	None	100m
									AA	6m	6m
									BB	10m	10m
									CC	15m	15m
									DD	20m	20m
									Cable end treatment		
									0	None	
									1	One side (detector side)	
									2	Both sides	

Note: For connection between detector and converter, the conduit to be used should be rainproof flexible type.

(Replacement Detector element)

ZFK				Description								
4	5	6	7	8	9	10	11	12	13			
R	2	4								Application		
										General use.		
										For corrosive gas (refuse in cinerator)		
										Cal. gas inlet		
										For φ1/4 inch tube		
										Power supply		
										100/115VAC 50/60Hz		
										200/220VAC 50/60Hz		
										230VAC 50/60Hz		

CONFIGURATION

Flow guide tube system

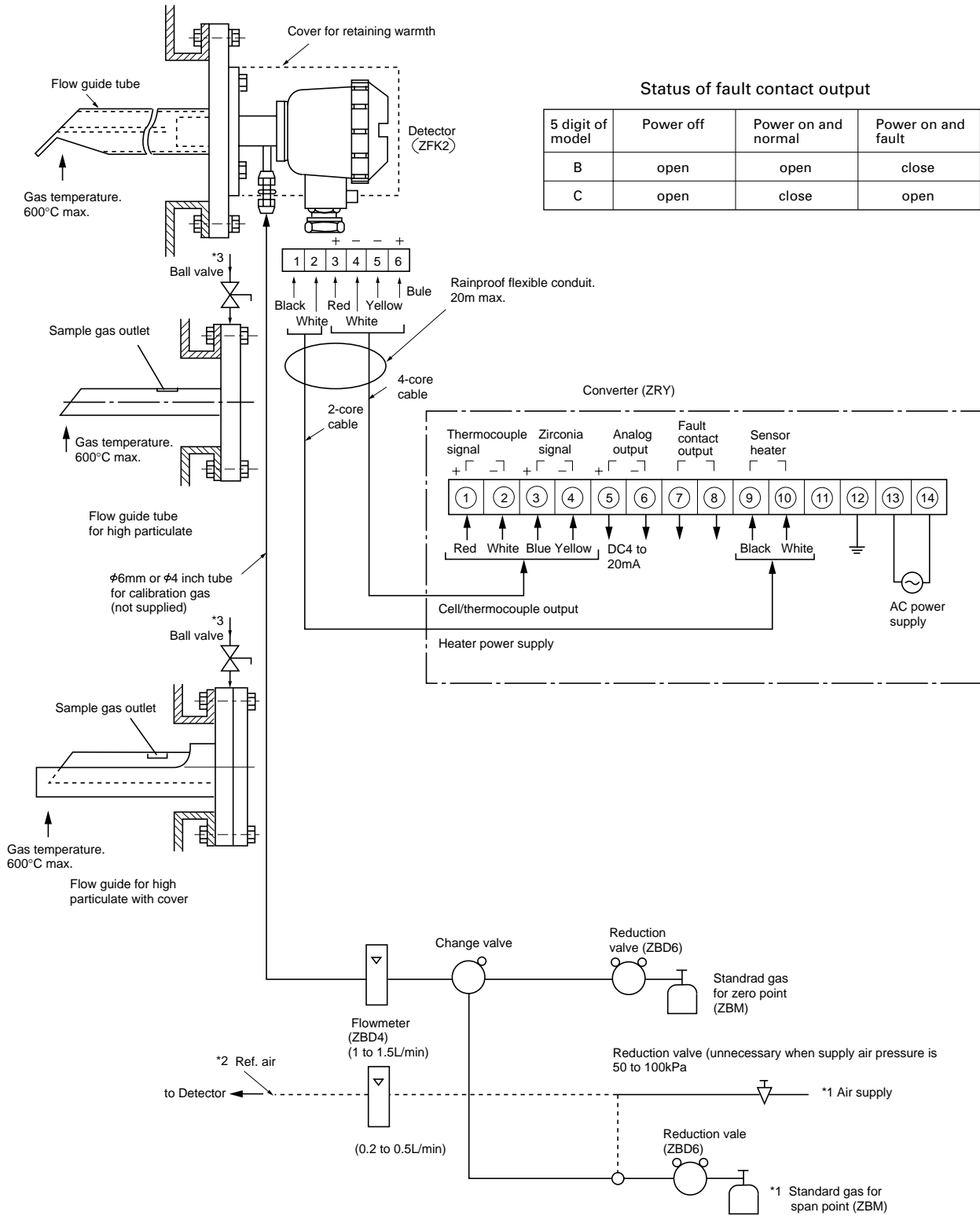

- Note
- *1 Standard gas or instrumentation air can be used in place of span gas.
 - *2 Instrument quality air or bottled air is available as reference air instead of ambient air, when oxygen concentration in air around sensor changes.
 - *3 Blow down air inlet pressure in 200 to 300kpa.

OUTLINE DIAGRAM (Unit:mm)

Detector (ZFK2)

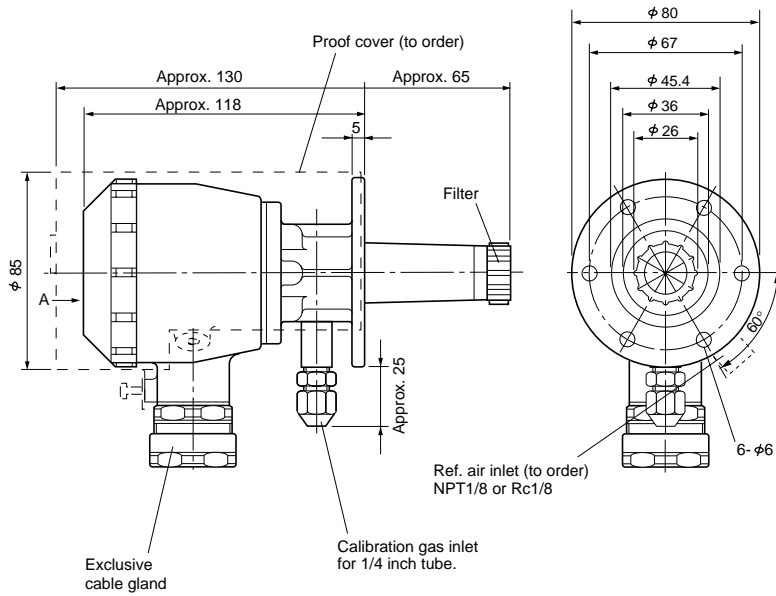

EXTERNAL CONNECTION DIAGRAM

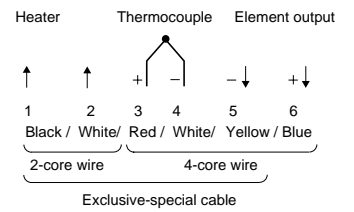

Flow guide tube

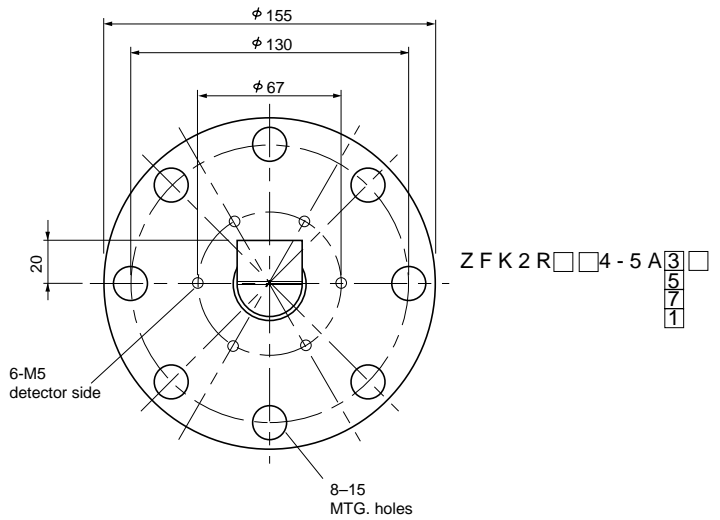
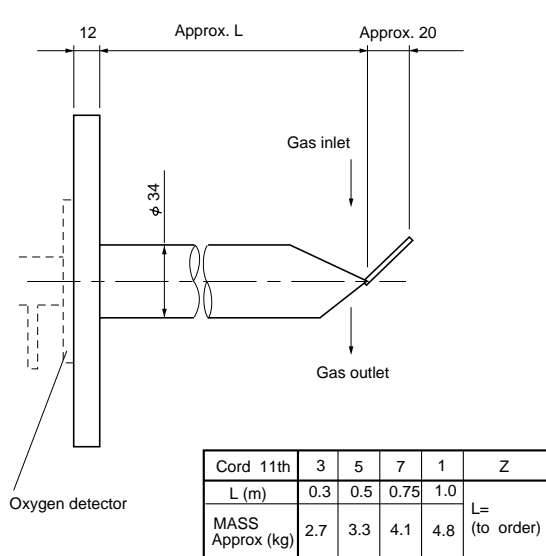

Detector (ZFK5)

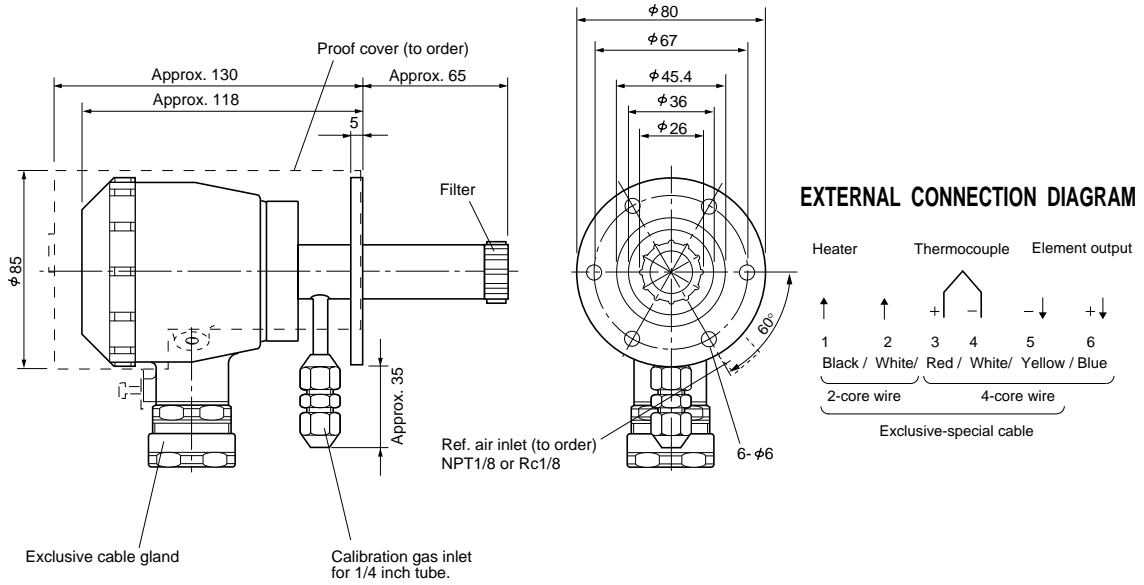

Flow guide tube

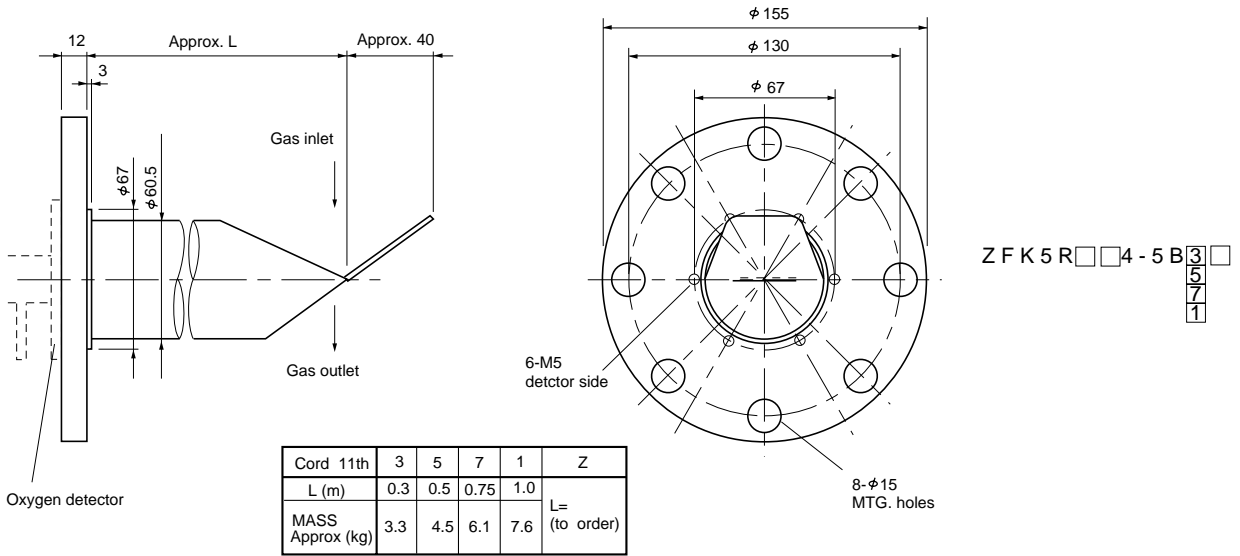

Flow guide tube (for high particulate)

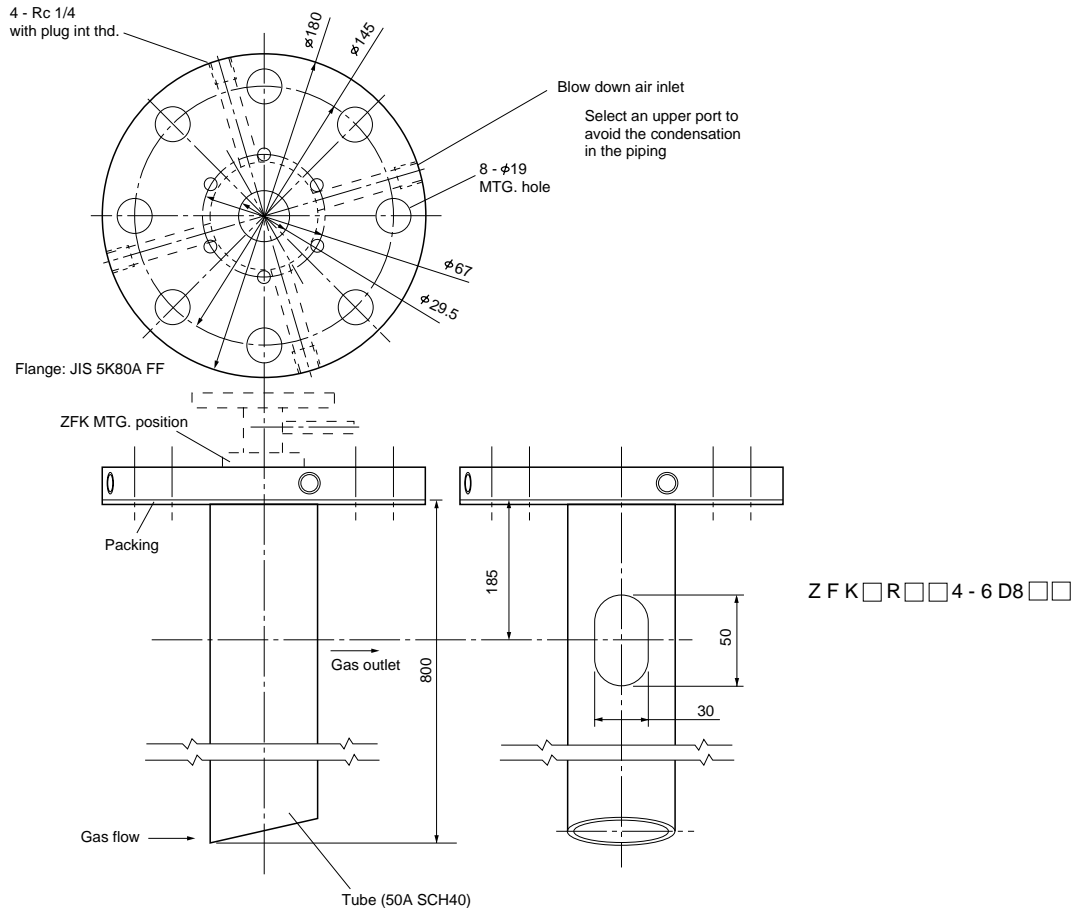

Flow guide tube (for high particulate with cover)

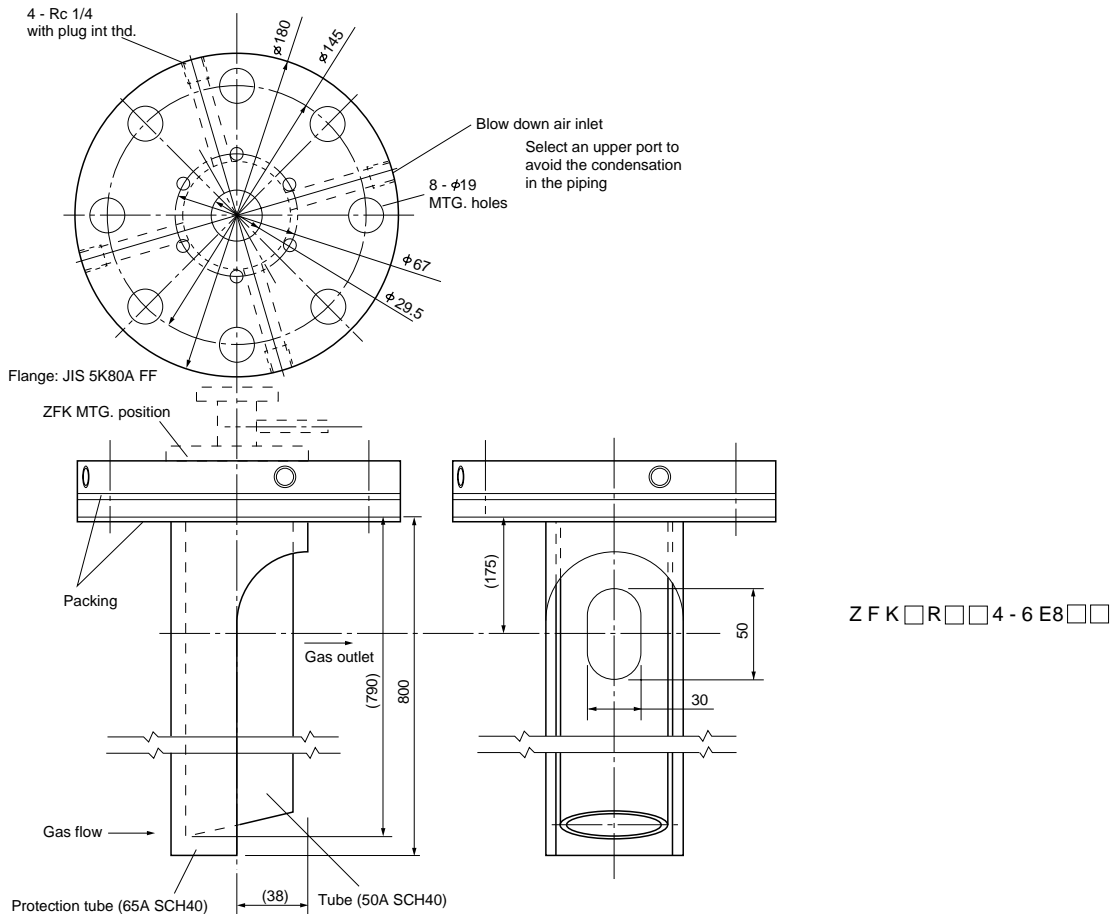

Converter (ZRY)

Panel flush mounted

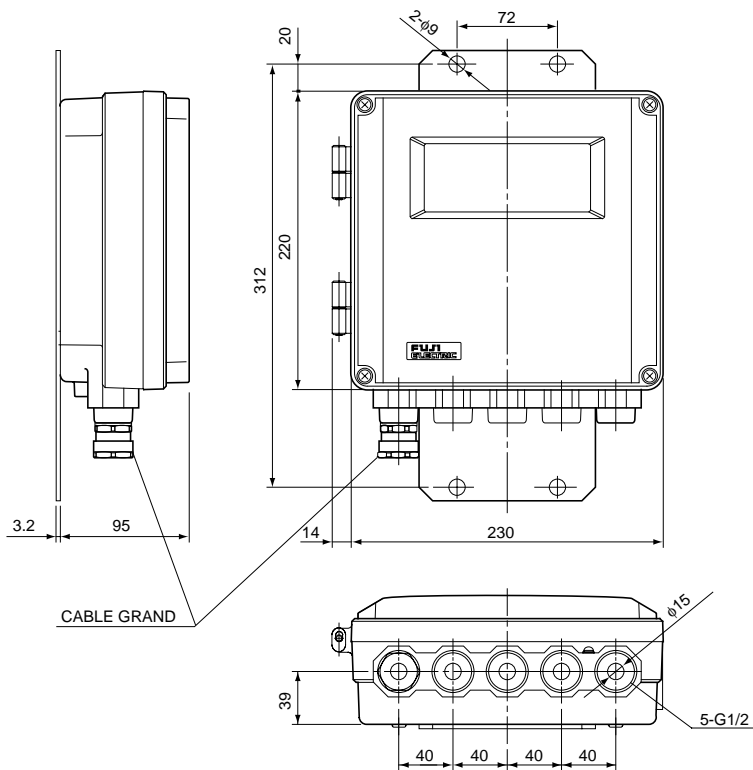

CONNECTION DIAGRAM

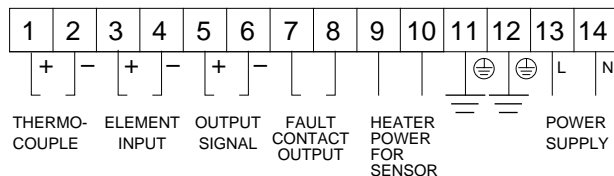

⚠ Caution on Safety

*Before using this product, be sure to read its instruction manual in advance.

Fuji Electric Systems Co., Ltd.

Head Office

Gate City Ohsaki, East Tower, 11-2, Osaki 1-chome,
Shinagawa-ku, Tokyo 141-0032, Japan

<http://www.fesys.co.jp/eng>

Instrumentation Div.

International Sales Dept.

No.1, Fuji-machi, Hino-city, Tokyo, 191-8502 Japan

Phone: 81-42-585-6201, 6202 Fax: 81-42-585-6187

<http://www.fic-net.jp/eng>

Information in this catalog is subject to change without notice.

Printed in Japan