

# IN-SITU ZIRCONIA OXYGEN ANALYZER

## DATA SHEET

ZFK8, ZKM, ZTA

This oxygen analyzer is used to continuously measure oxygen concentration in combustible exhaust gas of industrial boilers or furnaces, and is ideally suited for combustion management and control.

The analyzer system is comprised of the detector and converter coupled together as a complete system. Detector setting configuration includes the detector flow tube and detector sensor. The flow tube is inserted directly into the gas and directs gas to the sensor for measurement. The converter (ZKM) is comprised of the signal processor, input/output and communications, display and system controls.

The converter is equipped with advanced functionality such as performing the sensor diagnostics and sensor recovery function, so the detector can be used within long term stability.

## FEATURES

- Gas sampling device is unnecessary**  
For quick response, insert the detector directly into the flue Gas sampling functions such as a gas aspirator and a dehumidifier are not required.
- Easy maintenance**  
The sensor equipped with the detector, has unit construction, it is easy to replace.  
By separating the detector and the flow guide tube, filter replacement is easy.
- More reliable than sensor diagnosis, sensor recoverable function**  
Depending on the concentration of the measurement gas, the power of the sensor might deteriorate. The equipment includes sensor recovery function electronically, checking the deterioration status of the sensor depletion.  
Therefore, it has high reliability and long-lasting stability.
- Safe and secure**  
System detects thermocouple break for heater control on the sensor side. Safety functions of isolating power supply to the detector or isolating power via external contact input are also.
- Easy operation**  
The operation and setting for the converter can be performed interactively, and available as English, Japanese or Chinese for language display.

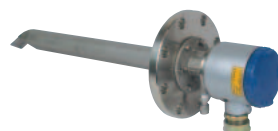

General-use detector  
(ZFK8)



High-temperature detector  
(ZTA)



<IP66>  
Converter (ZKM1)



<IP67>  
Converter (ZKM2)

## SPECIFICATIONS

### General Specifications

<b>Measuring object:</b>	Oxygen in noncombustible gas
<b>Measuring method:</b>	Directly insert type zirconia system
<b>Measuring range:</b>	0 to 2 ... setting range at option 2 in 50 vol% O <sub>2</sub> (in 1 vol% O <sub>2</sub> steps)
<b>Repeatability:</b>	Within ±0.5%FS
<b>Linearity:</b>	Within ±2%FS
<b>Response time:</b>	Within 4 to 7 sec, for 90% (from calibration gas inlet)
<b>Warmup time:</b>	More than 10 min
<b>Analog output:</b>	4 to 20mA DC (allowable load resistance less than 500Ω) or 0 to 1V DC (output resistance more than 100Ω)
<b>Power supply:</b>	Rated voltage; 100 to 120V AC (operating voltage 90 to 132V AC) 200 to 240V AC (operating voltage 190 to 264V AC) Rated frequency; 50/60Hz
<b>Power consumption:</b>	Maximum 240VA (Detector: approx. 200VA, Converter: approx. 40VA) Normal 70VA (Detector: approx. 50VA, Converter: approx. 20VA)

**Detector Specifications (ZFK)**

**Measured gas temperature:**

Flow guide tube system; -20 to +600°C (for general-use, corrosive gas)  
Ejector system; -20 to +1500°C (for high-temperature gas)  
-20 to +800°C (for general-use)

**Measured gas pressure:**

-3 to +3kPa (-306 to +306mmH<sub>2</sub>O)

**Flow guide tube:**

With or without blow-down nozzle  
Flange; JIS5K 65A FF  
(JIS5K-80AFF for high particulate gas)  
Insertion length; 0.3, 0.5, 0.75, 1m  
(0.8m for high particulate gas)

**Ejector (general-use):**

Probe for guiding measured gas to detector  
Flange; JIS10K 65A RF  
Insertion length; 0.5, 0.75, 1, 1.5m (according to customer's specification)

**Operating temperature:**

-10 to +60°C for Primary detecting element  
-5 to +100°C for ejector section  
125°C or less at detector flange surface with power applied

**Storage temperature:**

Sensing element: -20 to +70°C  
Ejector: -10 to +100°C

**Structure:**

Dust/rain-proof structure(IEC IP66 equivalent)

**Filter:**

Alumina(filtering accuracy 50µm) and quartz paper

**Main materials of gas-contacting parts:**

Detector; Zirconia, SUS316, platinum  
Flow guide tube; SUS304 or SUS316  
Ejector (general use); SUS316, SUS304  
Ejector; (for high temperature) SiC, SUS316, SUS304

**Calibration gas inlet:**

φ6mm tube join or φ1/4-inch tube join (as specified)

**Reference air inlet (option):**

φ6mm tube join or φ1/4-inch tube join (as specified)

**Detector mounting:**

Horizontal plane ±45°, ambient surrounding air should be clean.

**Outer dimensions:** (L × max. dia.) 210mm × 100mm (detector)

**Mass (approx.) {weight}:**

Detector; 1.6kg  
Ejector; 15kg (insertion length 1m)  
Flow guide tube (general-use, 1m); 5kg

**Finish color:**

Silver and SUS metallic color

**Ejector air inlet flow rate:**

5 to 10 L/min

**Calibration gas flow:**

1.5 to 2 L/min

**Blowdown air inlet pressure:**

200 to 300kPa {2 to 3 kgf/cm<sup>2</sup>}

**Ejector exhaust gas processing:**

Within furnace, returned to flue

**Heater temperature drop alarm output (ejector):**

Alarm output when below 100°C Me-

chanical thermostat

N.O. (1a) contact, 200V AC, 2A

**Converter specification (ZKM)**

**Concentration value indication:**

Digital indication in 4 digits

**Contact output signal:**

(1) Contact specification; 6 points, 1a 250V AC/3A or 30V DC/3A  
(2) Contact function;

- Under maintenance
- Under blowdown Note3)
- Span calibrating gas
- Zero calibration gas
- Instrument anomalies Note1)
- Alarm Note2)

Note1) The following Instrument errors (1) Thermocouples break (2) Sensor break (3) Temperature fault (4) Calibration fault (5) Zero/span adjustment fault (6) Output error turn the contact-ON

Note2) Alarm selects just one as mentioned below (1) High (2) Low (3) Upper and Lower (4) High-high (5) Low-low, it turns ON while operating.

Note3) Under blow down is available in case of option, and it turns ON while operating.

**Contact input signal:**

(1) Contact specification; 3points (the following option) ON; 0V (10mA or less), OFF; 5V

(2) Contact function;

- External hold
- Calculation reset
- Heater OFF
- Blow down (option)
- Inhibition of calibration
- Calibration start
- Range change

**Calibration method:**

- (a) Manual calibration with key operation
- (b) Auto. calibration (option)  
Calibration cycle; 00 day 00 hour to 99 days 23 hours
- (c) All calibration

**Calibration gas:**

- Range settings  
Zero gas; 0.010 to 25.00% O<sub>2</sub>  
Span gas; 0.010 to 50.00% O<sub>2</sub>
- Recommended calibration gas concentration  
Zero gas; 0.25 to 2.0% O<sub>2</sub>  
Span gas; 20.6 to 21.0% O<sub>2</sub>  
(oxygen concentration in the air)

**Blowdown:**

A function for blowing out with compressed air dust that has deposited in the flow guide tube. Blowdown can be performed for a predetermined time and at predetermined intervals.

**(option)**

Blowdown cycle; 00 hour 00 minute to 99 hours 59 minutes

Blowdown time; 0 minute 00 second to 0 minutes 999 seconds

**Output signal hold:**

Output signal is held during calibration, processing recoverable sensor, warm-up, and blowdown. The hold function can also be released.



(Converter)

1	2	3	4	5	6	7	8	9	10	11	Description	
Z	K	M										
	1											<b>Construction</b>
	2											IP66
												IP67
												<b>Output signal</b>
		B										4 to 20mA DC
		E										0 to 1V DC
		Z										Other
												<b>Communication function</b>
	1											RS-232C
	2											RS-485
												<b>Mounting bracket</b>
	1											Mounting on panel surface
	2											Pipe mounting
												<b>Optional Functions</b>
								Y				None
								1				Combustion efficiency display function Note4)
								2				Blowdown
								3				Auto calibration
								4				Combustion efficiency indication + Blowdown
								5				Combustion efficiency indication + Auto calibration
								6				Blowdown + Auto calibration
								7				Combustion efficiency indication + Blowdown + Auto calibration
												<b>Display language</b>
								J				Japanese
								E				English
								C				Chinese
												<b>Cock (Specify none when the analyzer has auto calibration function.)</b>
								Y				Without
								1				With (IP66 case)
								2				With (IP67 case)

Note4) When you select this display, rich mode will be a simultaneous display.

(Exclusive-special cable)

1	2	3	4	5	6	7	8	9	Description	
Z	R	Z	K	R						
										<b>Connectable devices</b>
										For ZKM
										<b>Types</b>
										For R thermocouple
										<b>Conduit length</b>
										<b>Cable length</b>
										YA --- None 6m
										YB --- None 10m
										YC --- None 15m
										YD --- None 20m
										YE --- None 30m
										YF --- None 40m
										YG --- None 50m
										YH --- None 60m
										YJ --- None 70m
										YK --- None 80m
										YL --- None 90m
										YM --- None 100m
										AA --- 6m 6m
										BB --- 10m 10m
										CC --- 15m 15m
										DD --- 20m 20m
										<b>Cable end treatment</b>
										0 --- None
										1 --- One side (detector side)
										2 --- Both sides

Note5) For connection between detector and converter, the conduit to be used should be rainproof flexible type.

(Ejector)

1	2	3	4	5	6	7	8	Description	
Z	T	A							
									<b>Measured gas temperature</b>
	1								For high temperatures (+1500°C max.)
	2								General-use (+800°C max.)
									<b>Insertion length [mm]</b>
						B			500
						C			750
						D			1000
						E			1500
									<b>Power supply</b>
	1								100V/115V AC 50/60Hz
	3								200V/220V AC 50/60Hz
	5								230VAC 50/60Hz

SCOPE OF DELIVERY

**Detector:** Detector main unit × 1, Viton O ring × 1, mounting screw (M5mm × 16) × 6, thermal sticker × 1, flow guide tube (as specified) × 1, ceramic filter × 1, rain-proof cover (as specified) × 1, Instruction manual × 1

**Converter:** Converter main unit × 1, mounting bracket set, (as specified) × 1  
Accessories (AC250V 500mA T fuse × 2, AC250V 2.5A T fuse × 2), Instruction manual × 1

**Ejector:** Ejector main unit × 1, insertion tube × 1, M16mm nut, and washer × 4, packing × 1

Items to be prepared separately:

- Standard gas for calibration  
Type ZBM□NSH4-01 (up to 5% O<sub>2</sub> range)  
Type ZBM□NSJ4-01 (over 5% O<sub>2</sub> range)
- Reduction valve for standard gas (type ZBD61003)
- Flowmeter  
Type; ZBD42203, 0.2 to 2L/min (for calibrating gas)  
Type; ZBD42403, 1 to 10L/min (for ejector)

CAUTIONS

- If combustible gas (CO, H<sub>2</sub> etc.) exists in the measured gas, error will occur due to burning at the sensor section. The inclusion of corrosive gas (Si vapor, alkaline metal, P, Pb etc.) will shorten the life of the sensor.
- When the measured gas temperature is high (+300°C or higher), the flange should be separated from the furnace wall in order to bring the detector flange surface temperature below the specified value (+125°C). The flow guide should be attached in the direction in which the gas flow to the detector decreases.
- When much dust is included in the gas, the flow guide tube should be attached at an inclination so that the flow goes from below to above. And the flow guide should be attached in the direction in which the gas flow to the detector decreases.
- In the case of a refuse incinerator, automatic blow down of the flow guide should not be performed (to prevent corrosion of the flow guide tube due to drainage). Blow-down should be performed manually when change in the indication has become very little with the furnace stopped.

# CONFIGURATION

## Flow guide tube system

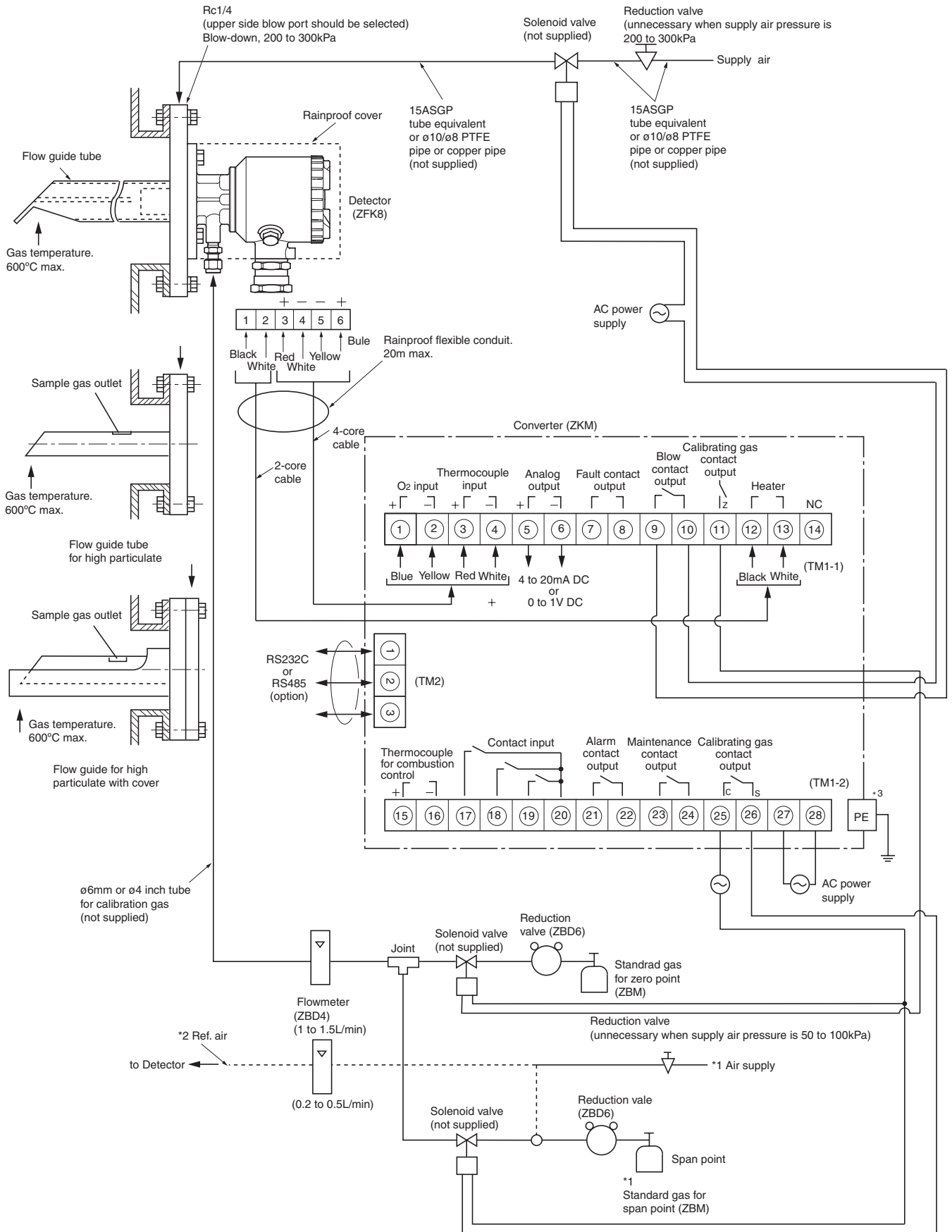

Note: \*1 Standard gas or instrumentation air can be used in place of span gas.  
 \*2 Instrument quality air or bottled air is available as reference air instead of ambient air.  
 \*3 Protective earth.

Ejector system

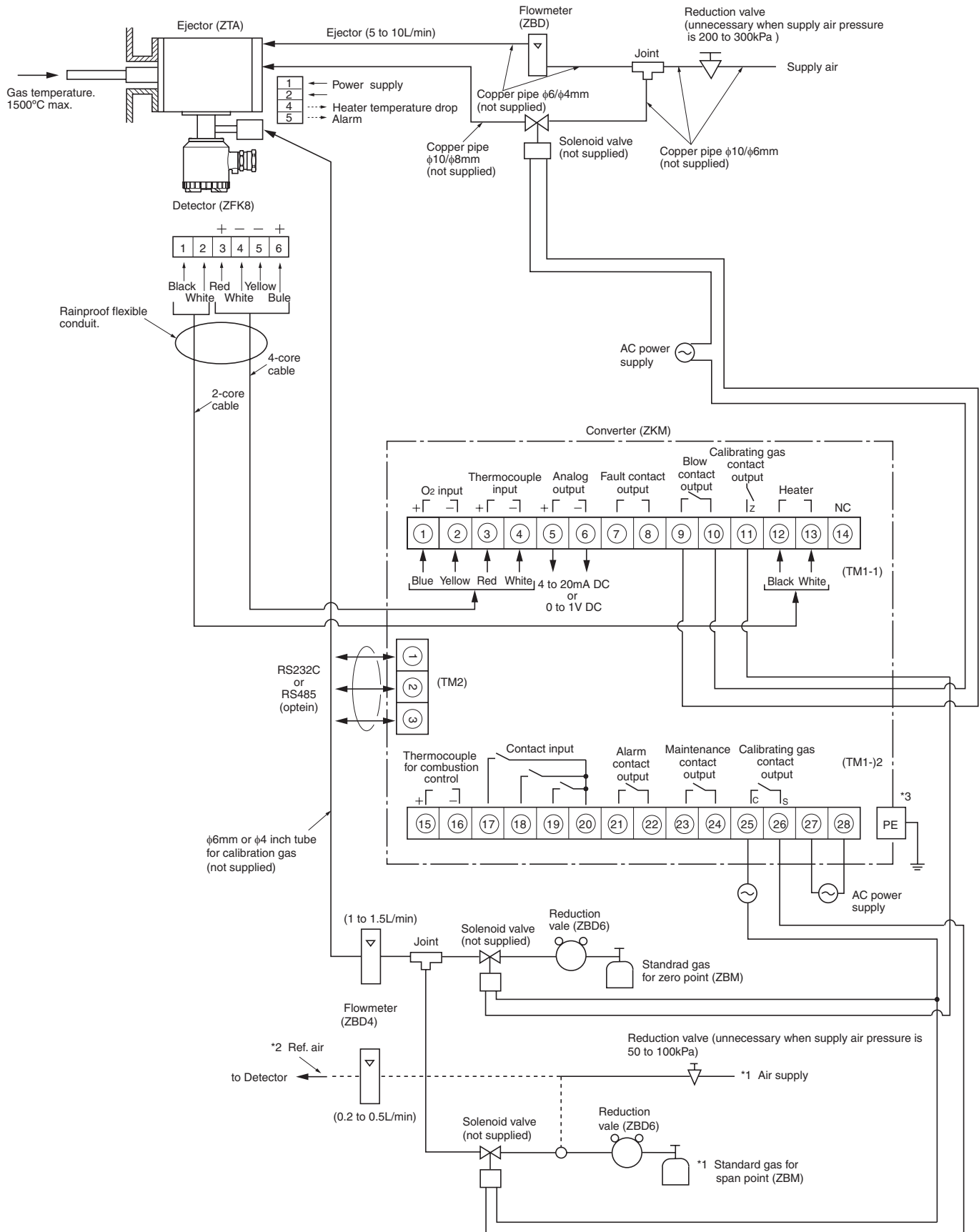

Note: \*1 Standard gas or instrumentation air can be used in place of span gas.  
 \*2 Instrument quality air or bottled air is available as reference air instead of ambient air.  
 \*3 Protective earth.

## DEVICE CONFIGURATION

The device to be combined differ according to the conditions of the gas to be measured. Select the devices to be combined with reference to the following table.

Application	Temperature	Gas Flow	Measured gas			Device configuration		
			DUST	Protection cover	Note	Detector type	Converter type	Ejector type
General-use (boiler)	600°C or less	5 to 20m/s	Less than 0.2g/m <sup>3</sup>	—	Fuel; gas, oil	ZFK8R□□5-□A5□□-1□	ZKM	—
			Less than 10g/Nm <sup>3</sup>	—	Fuel: coal with blow down	ZFK8R□□5-□C5□□-1□	ZKM	—
For corrosive gas (refuse incinerator)	600°C or less	5 to 20m/s	Less than 1g/Nm <sup>3</sup>	—	Included low moisture	ZFK8R□□5-□B5□□-2□	ZKM	—
			Less than 10g/Nm <sup>3</sup>	—	Included low moisture with blow down	ZFK8R□□5-□C5□□-2□	ZKM	—
			Less than 25g/Nm <sup>3</sup>	no	Included low moisture with blow down	ZFK8R□□5-□D6□□-2□	ZKM	—
			Less than 25g/Nm <sup>3</sup>	yes	Included high moisture with blow down	ZFK8R□□5-□E6□□-2□	ZKM	—
General-use (boiler)	800°C or less	Less than 1m/s	Less than 1g/Nm <sup>3</sup>	—	SUS316 tube with blow down	ZFK8R□□5-0Y0□□-1□	ZKM	ZTA1
	1590°C or less	Less than 1m/s	Less than 1g/Nm <sup>3</sup>	—	SIC tube with blow down	ZFK8R□□5-0Y0□□-1□	ZKM	ZTA2

Note (1) Dust volume is approximate value.

(2) Instrument quality air or bottled air is available as reference air by selecting detector with reference air inlet.







### Detector (ZFK8)

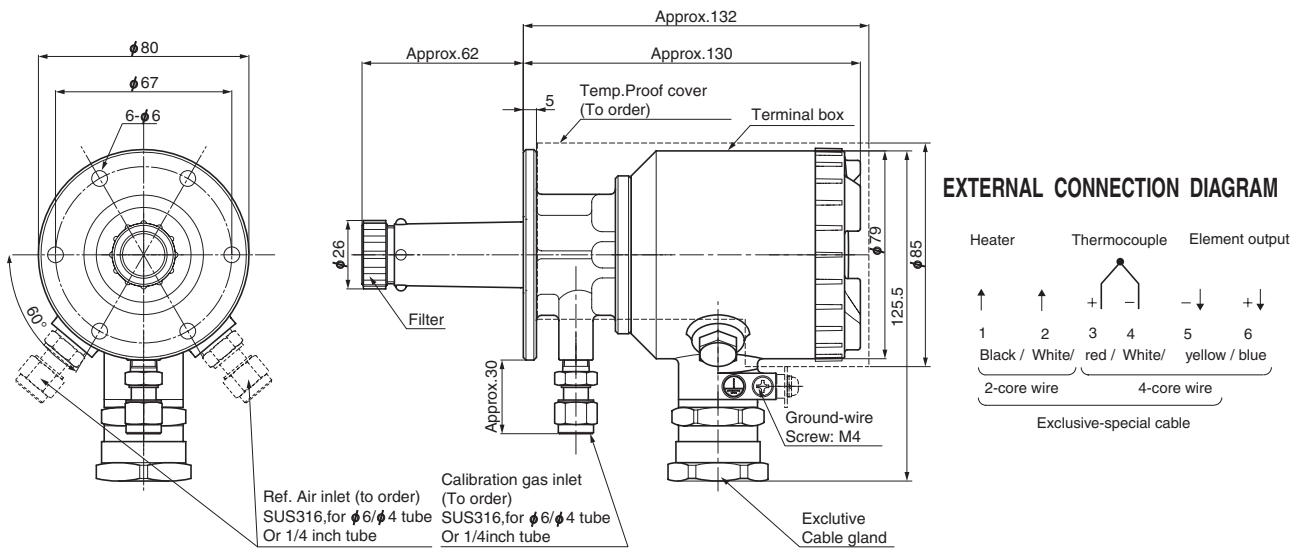

### Sensor unit (ZFK8YY)

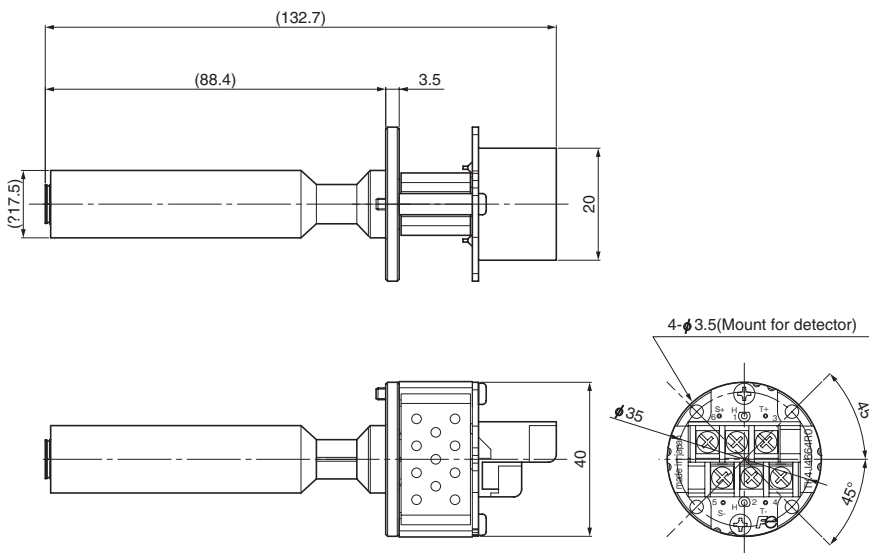

### Flow guide tube

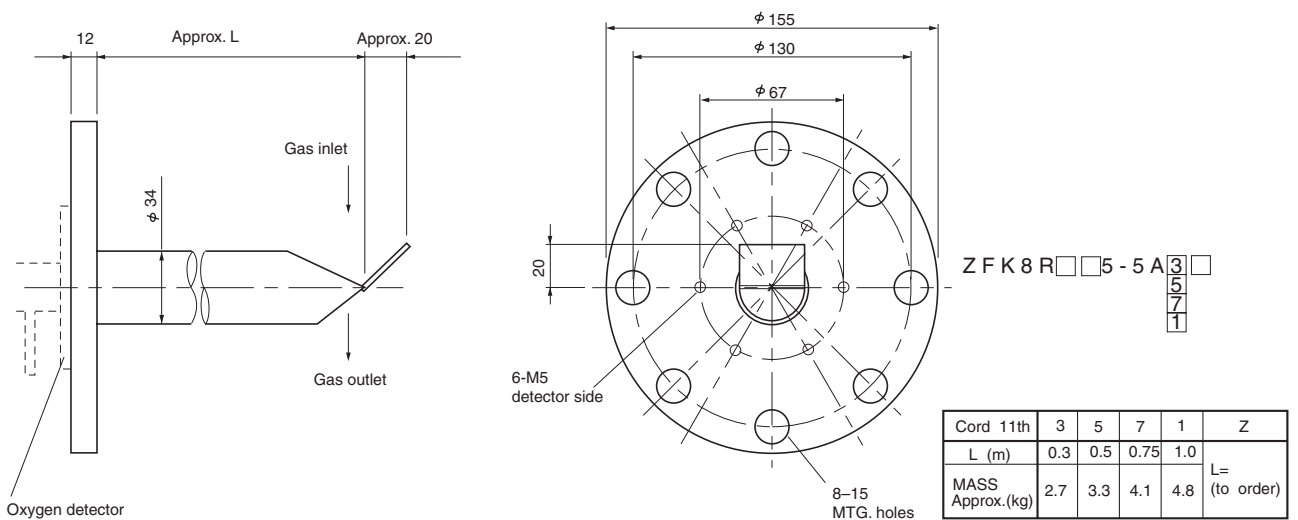

Flow guide tube (with blow-down nozzle)

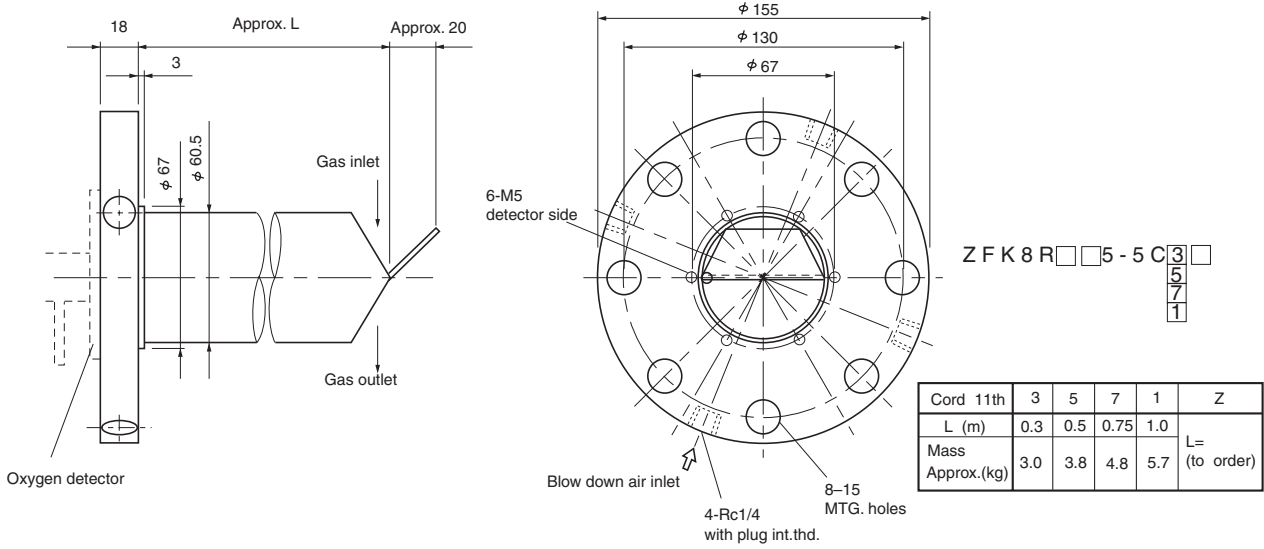

Flow guide tube (for high particulate)

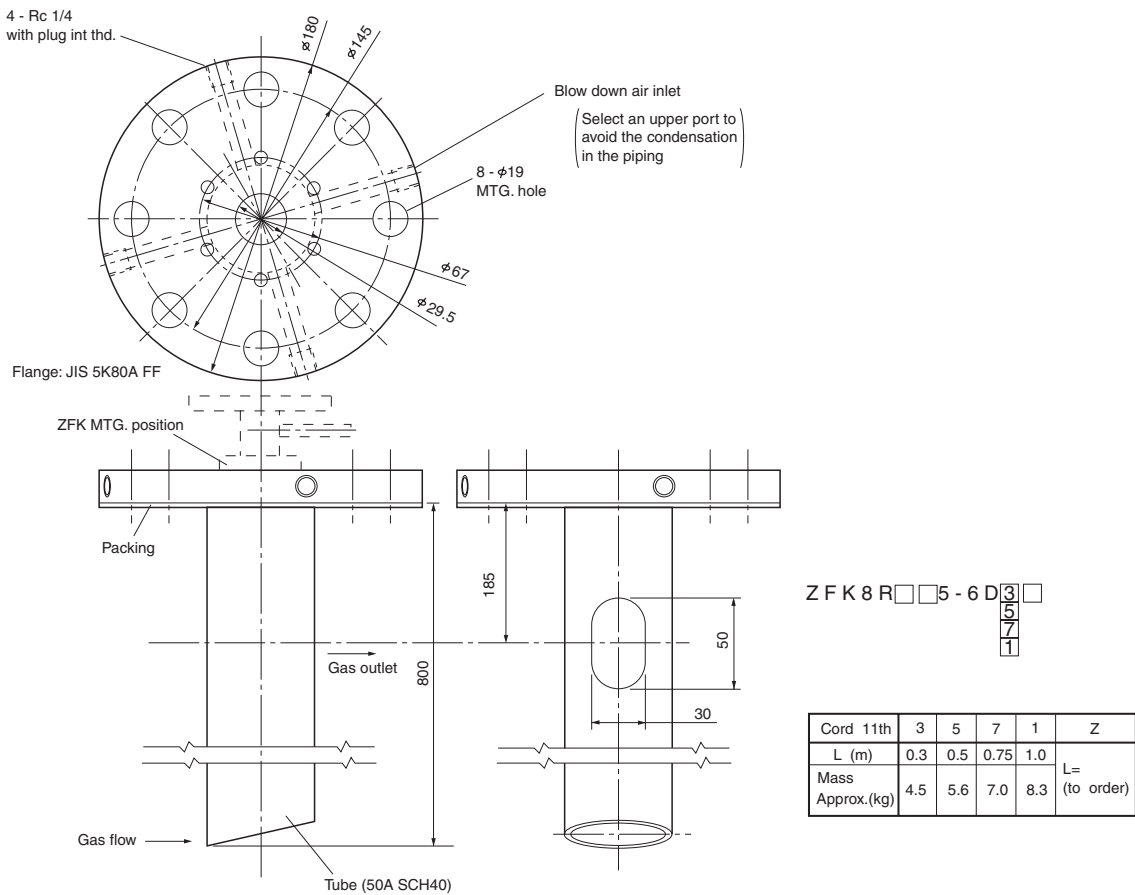

### Flow guide tube (for high particulate with cover)

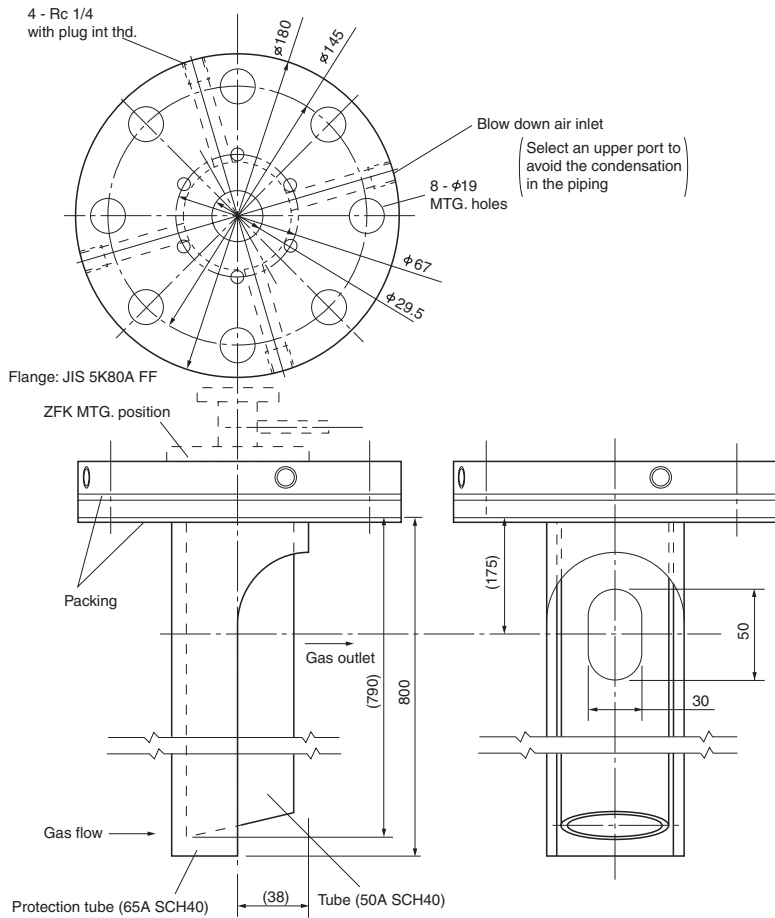

Z F K 8 R □ □ 5 - 6 E  $\begin{matrix} 3 \\ 5 \\ 7 \\ 1 \end{matrix}$  □

Cord 11th	3	5	7	1	Z
L (m)	0.3	0.5	0.75	1.0	L= (to order)
Mass Approx.(kg)	7.1	9.0	11.4	13.6	

### Flow guide tube

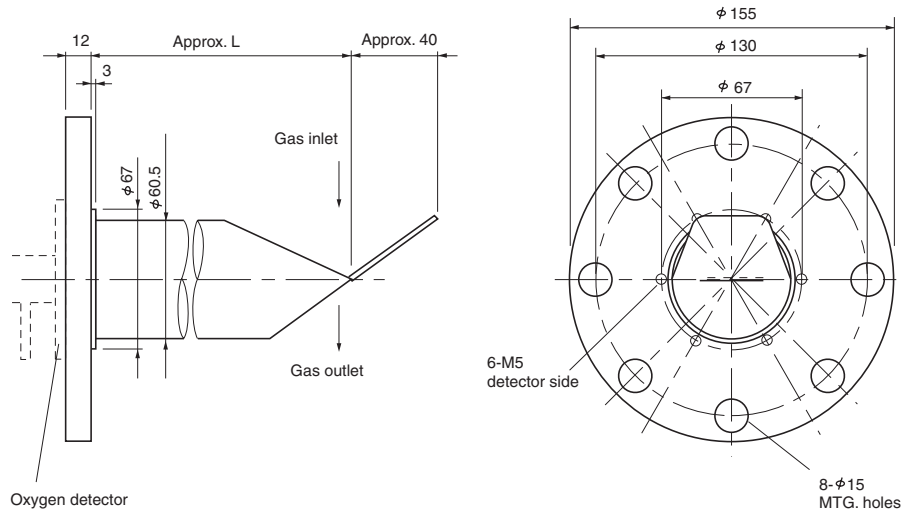

Z F K 8 R □ □ 5 - 5 B  $\begin{matrix} 3 \\ 5 \\ 7 \\ 1 \end{matrix}$  □

Cord 11th	3	5	7	1	Z
L (m)	0.3	0.5	0.75	1.0	L= (to order)
MASS Approx.(kg)	3.3	4.5	6.1	7.6	

Ejector (ZTA)

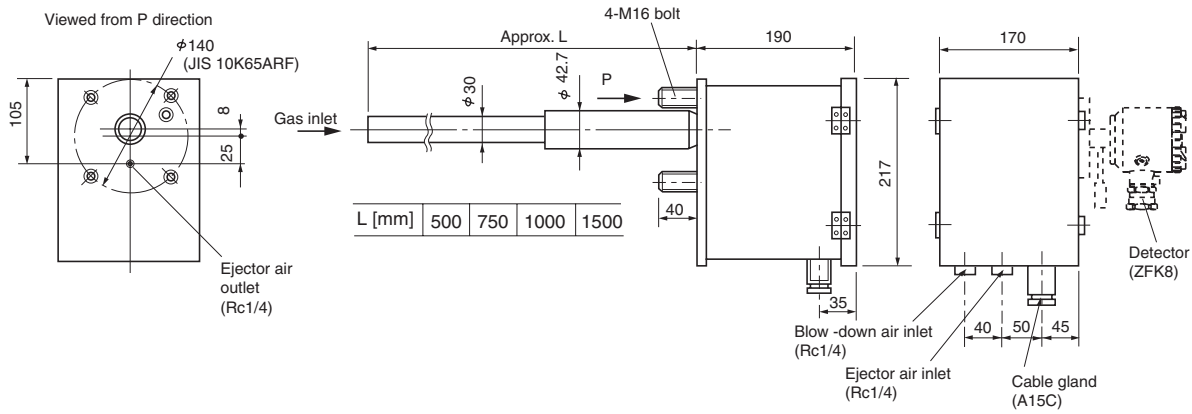

EXTERNAL CONNECTION DA DIAGRAM

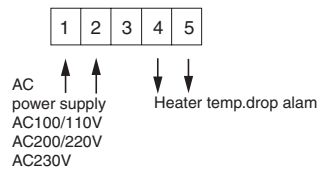

⚠ Caution on Safety

\*Before using this product, be sure to read its instruction manual in advance.

**Fuji Electric Systems Co., Ltd.**

**Sales Div. III, International Sales Group**  
**Global Business Group**

Gate City Ohsaki, East Tower, 11-2, Osaki 1-chome,  
Shinagawa-ku, Tokyo 141-0032, Japan

<http://www.fesys.co.jp/eng>

Phone: 81-3-5435-7280, 7281 Fax: 81-3-5435-7425

<http://www.fic-net.jp/eng>